

CATALYST ACADEMY OF LIFE SCIENCES [CALs], MUMBAI

Hunt knowledge and the success will chase you.



Mb: +91-84249 18965; Website: www.calsnetexam.in & www.calsnetexam.com

Email: cals.netexam@gmail.com

CSIR NET LIFE SCIENCES Solved paper June 2015 Booklet- B

Part A

1. What is angle x in the schematic diagram given below?

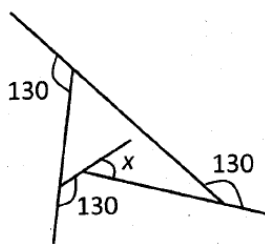

- (1) 60 (2) 50
(3) 40 (4) 30

2. A 3 m long car goes past a 4 m long truck at rest on the road. The speed of the car is 7 m/s. The time taken to go past is

- (1) 4/7 (2) 1 s
(3) 7/4 s (4) 10/7 s

3. Of three persons A, B and C, one always lies while the others always speak the truth. C asked A, "Do you always speak the truth, yes or no?" He said something that C could not hear. So, C asked B, "what did A say?" B replied, "A said No. So, who is the liar?"

- (1) A (2) B
(3) C (4) cannot be determined

4. Consider 3 parallel strips of 10m width running around the Earth, parallel to the equator; A1 at the Equator, A2 at the Tropic of Cancer and A3 at the Arctic Circle. The order of the areas of the strips is

- (1) $A1 < A2 < A3$ (2) $A1 = A2 > A3$
(3) $A1 > A2 = A3$ (4) $A1 > A2 > A3$

5. A pyramid shaped toy is made, by tightly placing cubic blocks of $1 \times 1 \times 1 \text{ cm}^3$. The base of the toy is a square $4 \times 4 \text{ cm}^2$. The width of each step is 0.5 cm. How many blocks are required to make the toy?

- (1) 30 (2) 34
(3) 36 (4) 40

6. A single celled spherical organism contains 70% water by volume. If it loses 10% of its water content,

how much would its surface area change by approximately?

- (1) 3% (2) 5%
(3) 6% (4) 7%

7. Two plane mirrors facing each other are kept at 60° to each other. A point is located on the angle bisector. The number of images of the point is

- (1) 6 (2) 3
(3) 5 (4) Infinite

8. Suppose

- (1) $x = 4$
(2) Then $x - 4 = x^2 - 42$ (as both sides are zero)
(3) Therefore $(x - 4) = (x - 4)(x + 4)$
Cancelling $(x - 4)$ from both sides (4) $1 = (x + 4)$
(5) Then $x = -3$

Which is the wrong step?

- (1) 1 to 2 (2) 2 to 3
(3) 3 to 4 (4) 4 to 5

9. Let m and n be two positive integers such that $m + n + mn = 118$. Then the value of $m + n$ is

- (1) not uniquely determined
(2) 18
(3) 20
(4) 22

10. From a group of 40 players, a cricket team of 11 players is chosen. Then, one of the eleven is chosen as the captain of the team. The total number of ways this can be done is $\left[\binom{m}{n} \right]$ below means the number of ways n objects can be chosen from m objects]

- (1) $\binom{40}{11}$
(2) $11 \binom{40}{11}$
(3) $29 \binom{40}{11}$
(4) $\binom{39}{11}$

11. I bought a shirt at 10% discount and sold it to a friend at a loss of 10%. If the friend paid me Rs. 729.00 for the shirt, what was the undiscounted price of the shirt?

- (1) Rs. 900 (2) Rs. 800
(3) Rs. 1000 (4) Rs. 911.25

12. Jar W contains 40 white - marbles and contains 40 black marbles. Ten black from B are transferred to W and mixed thoroughly. Now, ten randomly selected marbles from W are put back in Jar B to make 40 marbles in each jar. The number of black marbles in W
- (1) would be equal to the number of marbles in B.
 - (2) would be more than the number of white marbles in B
 - (3) would be less than the number of white marbles in B
 - (4) cannot be determined from the information given

13. How many non-negative integers less than 10,000 are there such that the sum of the digits of the number is divisible by three?
- (1) 1112
 - (2) 2213
 - (3) 2223
 - (4) 3334

14. if $aN \Rightarrow S$
 $eF \Rightarrow I$
 $gH \Rightarrow M$
 then $nS = ?$
- (1) T
 - (2) A
 - (3) L
 - (4) K

15. In each of the following groups of words is a hidden number, based on which you should arrange them in ascending order. Pick the right answer: A. Tinsel event B. Man in England C. Good height D. Last encounter
- (1) A, B, C, D
 - (2) C, B, D, A
 - (3) A, C, D, B
 - (4) C, D, B, A

16. Two ants, initially at diametrically opposite points A and B on a circular ring of radius R, start crawling towards each other. The speed of the one at A is half of that of the one at B. The point at which they meet is at a straight line distance of

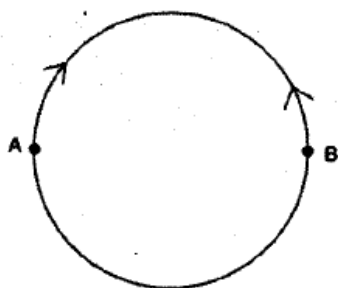

- (1) R from A
 - (2) $3R/2$ from A
 - (3) R from B
 - (4) $3R/2$ from B
17. Starting from a point A you fly one mile south, then one mile east, then one mile north which brings you back to point A. Point A is NOT the north pole. Which of the following MUST be true?
- (1) You are in the Northern Hemisphere
 - (2) You are in the Eastern Hemisphere
 - (3) You are in the Western Hemisphere
 - (4) You are in the Southern Hemisphere

18. Information in DNA is in the form of sequence of 4 bases namely A, T, G and C. The proportion of G is the same as that of C, and that of A is the same as that of T. Which of the following strands of DNA will potentially have maximum diversity (i.e., maximum information content per-base)?
- (1) length 1000 bases with 10% G
 - (2) length 2000 bases with 10% A
 - (3) length 2000 bases with 40% T
 - (4) length 1000 bases with 25% C

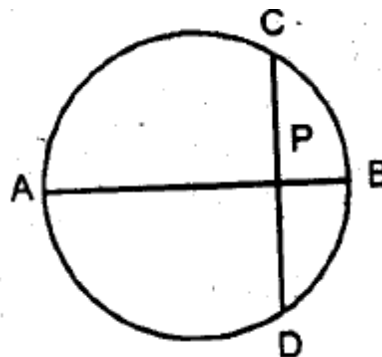

19. AB is the diameter of a circle. The chord CD is perpendicular to AB intersecting it at P. If CP = 2 and PB = 1, the radius of the circle is
- (1) 1
 - (2) 2.5
 - (3) 2
 - (4) 5

20. Based on the graph, which of the following statements is NOT true?

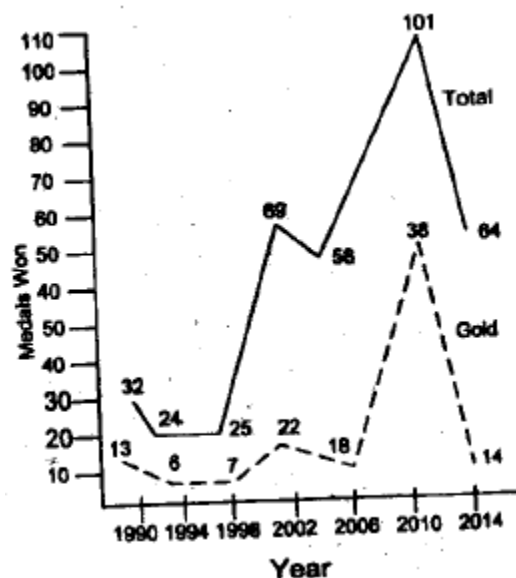

- (1) Number of gold medals increased whenever total number of medals increased
- (2) Percentage increase in gold medals in 2010 over 2006 is more than the corresponding increase in total medals
- (3) Every time non-gold medals together account for more than 50% of the total medals
- (4) Percentage increase in gold medals in 2010 over 2006 is more than the corresponding increase in 2002 over 1998

PART 'B'

21. Which one of the following statements about LEAFY (LFY), a regulatory gene in *Arabidopsis thaliana*, is correct?

- (1) LEAFY (LFY) is involved in floral meristem identity
- (2) LEAFY (LFY) is involved in leaf expansion.
- (3) LEAFY (LFY) is involved in root meristem identity.
- (4) LEAFY (LFY) is responsible for far-red light mediated seedling growth.

22. Dark-grown seedlings display 'triple response' when exposed to ethylene. Which one of the following is NOT a part of 'triple response'?

- (1) Decrease in epicotyl elongation.
- (2) Rapid unfolding and expansion of leaves.
- (3) Thickening of shoot.
- (4) Horizontal growth of epicotyl.

23. Which one of the following compounds is generally translocated in the phloem?

- (1) Sucrose
- (2) D-Glucose
- (3) D-Mannose
- (4) D-Fructose

24. The quantum yield of oxygen evolution during photosynthesis drastically drops in far-red light. This effect is known as:

- (1) Far red drop.
- (2) Red drop.
- (3) Blue drop.
- (4) Visible spectrum drop.

25. Given below are some statements about prokaryotic and eukaryotic mobile genetic elements or transposons.

- A. Most mobile genetic elements in bacteria transpose via an RNA intermediate.
- B. Most mobile genetic elements in bacteria are DNA.
- C. Mobile genetic elements in eukaryotes are only retrotransposons.
- D. Both, RNA and DNA transposons are found in eukaryotes.

Choose the correct combination.

- (1) A and C
- (2) B and C
- (3) A and D
- (4) B and D

26. Nitrogen gas is reduced to ammonia by nitrogen fixation' method. In order to execute the process, which one of the following compounds is usually required?

- (1) ATP
- (2) GTP
- (3) UDP
- (4) ADP

27. A 1% (w/v) solution of a sugar polymer is digested by an enzyme (20 μ g, MW=200,000). The rate of monomer sugar (MW=400) liberated was determined to have a maximal initial velocity of 10 mg formed/min. The turnover number (min⁻¹) will be

- (1) 5×10^4
- (2) 2.5×10^2
- (3) 4.0×10^{-6}
- (4) 2.5×10^5

28. The S wave of normal human ECG originates due to

- (1) septal and left ventricular depolarization.
- (2) late depolarization of the ventricular walls moving back toward the AV junction.
- (3) left to right septal depolarization.
- (4) repolarization of atrium.

29. In an alpha helical polypeptide, the backbone hydrogen bonds are between

- (1) NH of n and CO of n + 4 amino acids
- (2) CO of n and NH of n + 3 amino acids
- (3) CO of n and NH of n + 4 amino acids
- (4) NH of n and CO of n + 3 amino acids

30. Cystic fibrosis transmembrane conductance regulator (CFTR) is known to control the transport of which ion?

- (1) Ca²⁺
- (2) Mg²⁺
- (3) HCO³⁻
- (4) Cl⁻

31. Which one of the following enzymes is NOT a part of pyruvate dehydrogenase enzyme complex in glycolysis pathway?

- (1) Pyruvate dehydrogenase.
- (2) Dihydrolipoyl transferase.
- (3) Dihydrolipoyl dehydrogenase.
- (4) Dihydrolipoyl oxidase.

32. Following are three single stranded DNA sequences that form secondary structures.

- (a) ATTGAGCGATCAAT
- (b) ATTGAGCGATATCAAT
- (c) AGGGAGCGATCCCT

Based on their stability, which one is correct?

- (1) (a) = (b) = (c)
- (2) (c) > (a) > (b)
- (3) (b) > (c) = (a)
- (4) (b) > (c) > (a)

33. What phenotype would you predict for a mutant mouse lacking one of the genes required for sitespecific recombination in lymphocytes?

- (1) Decrease in T cell counts
- (2) Immunodeficient
- (3) Increase in T cell counts
- (4) Increase in B cell counts

34. Beating of cilia is regulated by

- (1) actin
- (2) myosin
- (3) cofilin
- (4) Nexin

35. The key determinant of the plane of cytokinesis in mammalian cells is the position of

- (1) chromosomes
- (2) central spindle
- (3) centrioles
- (4) pre-prophase band

36. Which one of the following events NEVER activates the G-protein coupled receptor for sequestering Ca²⁺ release?

- (1) Interaction of bind in to sperm receptors.
- (2) Activation of Frizzled by Wnt.

- (3) Cortical reaction blocking polyspermy
(4) DNA synthesis and nuclear envelope breakdown.
37. In type II splicing
(1) a 'G-OH' from outside makes a nucleophilic attack on 5'-P of first base of intron,
(2) a free 2'-OH of an internal adenosine makes a nucleophilic attack On 5'-P of first base of intron
(3) A 3'-OH of an internal adenosine makes a nucleophilic attack on 5'-P of first base of intron
(4) the hydrolysis of last base of exon is carried out by U2/U4/U6
38. The main difference between normal and transformed cells $A = \pi r^2$
(1) immortality and contact inhibition
(2) shorter generation time and cell mobility
(3) apoptosis and tumour suppressor gene hyperfunction.
(4) inactivation of oncogenes and shorter cell cycle duration
39. Hydra shows morphallactic regeneration and involves which one of the following signal transduction pathway in its axis formation?
(1) Wnt/ β -catenin pathway (2) Retinoic acid pathway
(3) FGF pathway (4) Delta-Notch pathway
40. When bacteria growing at 20°C are warmed at 37°C, they are most likely to synthesize membrane lipids with more
(1) short chain saturated fatty acids
(2) short chain unsaturated fatty acids
(3) long chain saturated fatty acids
(4) long chain unsaturated fatty acids
41. The mammalian oocyte prior to sperm entry is arrested at what stage of cell division?
(1) Prophase of mitosis
(2) Prophase of meiosis I
(3) G1 phase of mitotic cell cycle
(4) Metaphase of meiosis II
42. The pluripotency of the inner cell mass in mammals is maintained by a core of three transcription factors namely,
(1) Oct 4, Sox 2 and Nanog
(2) Oct 4, Sox 2 and Cdx2
(3) Sox 2, Nanog and Cdx2
(4) Oct 4, Cdx2 and Nanog
43. Which one of the following skeletal muscles of human body contains highest number of muscle fibre in a motor unit?
(1) Muscles of hand (2) Extraocular muscles
(3) Muscles of leg (4) Muscles of face
44. Copying errors occurring during replication are corrected by the proof reading activity of DNA polymerases that recognize incorrect bases
(1) at the 5' end of the growing chain and remove them by 5'→3'exonuclease activity.
(2) at the 3' end of the growing chain and remove them by 5'→3'exonuclease activity
(3) at the 3' end of the growing chain and remove them by 3'→5'exonuclease activity
(4) at the 5' end of the growing chain and remove them by 3'→5'exonuclease activity
45. In which of the following conditions is Basal Metabolic Rate (BMR) the lowest?
(1) Awake and resting
(2) Prolonged starvation
(3) Sleep
(4) Higher environmental temperature
46. In bacteria, heat-shock response is primarily controlled by
(1) Sigma S (σ S) (2) Sigma 32 (σ 32)
(3) Sigma E (σ E) (4) Sigma 70 (σ 70)
47. During each cycle of chain elongation in translation, how many conformational changes does the ribosome undergo that are coupled to GTP hydrolysis?
(1) Zero (2) One
(3) Two (4) Three
48. Which one of the following combinations must be present in a steroid receptor that is located in the cytoplasm?
(1) Nuclear export sequence (NES), leucine zipper
(2) NES, zinc finger motif
(3) Nuclear localization sequence (NLS), zinc finger motif
(4) NLS, leucine zipper
49. Segregation of alleles can occur at Anaphase I or at Anaphase n of meiosis. With reference to this statement, which one of the following organism is an ideal model system for identifying stage of allelic segregation at meiosis?
(1) *Neurospora crassa*
(2) *Saccharomyces cerevisiae*
(3) *Drosophila melanogaster*
(4) *Pisum sativum*
50. Collagens are the most abundant component of the extracellular matrix. In order to maintain normal physiological processes like wound healing, bone development, etc., which one of the following type of enzymes is MOST important?
(1) Peptidases (2) Proteases
(3) Amylase (4) Lipases
51. The most commonly used molecular tool for phylogenetic analysis involves sequencing of

- (1) mitochondrial DNA.
- (2) mitochondrial RNA.
- (3) ribosomal RNA.
- (4) nuclear DNA.

52. Which of the following is NOT semelparous?

- (1) Dracena (2) Bamboo
- (3) Cicada (4) Mayfly

53. The general relation between generation time (T) and population growth rate (r) is described by the equation

- (1) $\ln r = \ln a - b \ln T$ (2) $r = a - bT$
- (3) $\ln r = \ln a + b \ln T$ (4) $r = a + bT$

54. The dynamics of any subpopulation within a metapopulation differs from that of a normal population in that the

- (1) birth rates are lower than the death rates.
- (2) death rates are lower than the birth rates.
- (3) immigration and emigration rates are significantly higher.
- (4) immigration and emigration rates are negligible.

55. Which of the following is likely to contribute to the stability of an ecosystem?

- (1) High number of specialists
- (2) Fewer number of functional links
- (3) More omnivores
- (4) Linear rather than reticulate food webs

56. Genes A, B and C. control three phenotypes which assort independently; A plant with the genotype Aa Bb Cc is selfed. What is the probability for progeny which show the dominant phenotype for AT LEAST ONE of the phenotypes controlled by genes A, B and C?

- (1) 1/64 (2) 27/64
- (3) 63/64 (4) Cannot be predicted

57. Hybrid dysgenesis in *Drosophila* is caused by P-elements. Which one of the following crosses between different cytotypes will lead to dysgenesis?

- (1) M-cytotype x M-cytotype
- (2) M-cytotype x P-cytotype
- (3) P-cytotype x M-cytotype
- (4) P-cytotype x P-cytotype

58. A researcher would like to monitor changes in the level of a serum protein for, which an antibody is available. Which one of the following methods would be best suited for the purpose?

- (1) Immunofluorescence microscopy
- (2) Fluorescence in situ hybridization
- (3) Enzyme linked immunosorbent assay.
- (4) Fluorescence activated cell sorting

59. What will happen if DNA is labeled by nick translation while doing DNA foot- printing?

- (1) Nick translation will facilitate better analysis because entire DNA will be labeled and proteins

binding at any region of DNA can be demarcated with precision.

(2) This will allow arranging the DNA fragment in the desired order.

(3) Labeling by random priming may be advantageous as it generates smaller fragments which can penetrate tissue easily.

(4) The linear order of fragments from 5' → 3' end of DNA cannot be arranged.

60. Two groups (Control, Treated) are to be compared to test the effect of a treatment. Since individual variability is high in both groups, the appropriate statistical test to use is

- (1) Analysis of variance.
- (2) Kendall's test.
- (3) Student's t-test.
- (4) Mann-Whitney U-test.

61. Which one of the following viruses cause acute gastrointestinal illness due to contamination of drinking water?

- (1) Norovirus (2) Poliovirus
- (3) Rotavirus (4) Filoviruses

62. In an experiment, clones of a plant is grown in a field. The plants were observed to be of different heights. When a graph was plotted for frequency of plants (Y-axis) against different heights (X-axis), a bell-shaped curve was obtained. From the above, it can be concluded that the observed variation in height is due to

- (1) it being a polygenic trait
- (2) environmental effect
- (3) variation in genotype.
- (4) influence of environment on different genotypes

63. A protein has one tryptophan and one, tyrosine in its sequence. Assume molar extinction coefficients at 280 nm of tryptophan and tyrosine as 3000 and 1500 $M^{-1}cm^{-1}$, respectively. What would be the molar concentration of that protein if its absorption at 280 nm is 0.90?

- (1) 2 mM (2) 0.4 mM
- (3) 0.2 mM (4) 0.02 mM

64. The phylum in which the animals are bilaterally symmetrical in the larval stage and radially symmetrical in the adult stage is

- (1) Coelenterata. (2) Nematoda.
- (3) Mollusca. (4) Echinodermata.

65. In eusocial insects, males develop from unfertilized eggs while females develop from fertilized eggs. The ultimate consequence of this difference is that

- (1) in any colony there are always more males than females. .
- (2) a female is genetically more closely related to her sister than to her own offspring.

(3) females are behaviorally more dominant than the males.

(4) in any colony there are always more females than males.

66. According to which evolutionary theory, there are long periods without significant –evolutionary changes interrupted by short episodes of rapid evolution?

- (1) Punctuated equilibrium (2) Saltation
(3) Mutation (4) Neutrality

67. An extraordinary sensory ability that elephants possess is.

- (1) emission and detection of ultra high frequency sounds.
(2) emission and detection of ultra low frequency sounds.
(3) detection of changes in earth's magnetic field.
(4) possession of ultraviolet vision.

68. The mean (μ) and standard deviation (σ) of body size in a *Drosophila* population are 8.5 and 2.2 mm, respectively. Under natural selection over many generations the μ and σ of body size change to 8.5 and 0.8 mm, respectively. The type of natural selection responsible for the change is called

- (1) directional. (2) neutral.
(3) disruptive. (4) stabilizing.

69. Which of the following fungal groups has septate hyphae and reproduces asexually by budding, conidia and fragmentation?

- (1) Basidiomycota (2) Zygomycetes
(3) Chytrids (4) Glomeromycota

70. Which one of the methods listed below is the most sensitive label-free quantification method for proteins

- (1) UV spectroscopy (2) Infra-red spectroscopy
(3) Raman spectroscopy (4) ^{13}C content of protein

PART-C

71. Lipid rafts are involved in signal transduction in cells. Rafts have composition different from rest of the membrane. Rafts were isolated and found to have cholesterol to sphingolipid ratio of 2:1. The estimated size of the raft is 35 nm^2 . If the surface areas of cholesterol is 40 \AA^2 and sphingolipid is 60 \AA^2 , how many cholesterol and sphingolipids are present in one raft?

- (1) 50 cholesterol; 25 sphingolipid
(2) 200 cholesterol: 100 sphingolipid
(3) 40 cholesterol : 20 sphingolipid
(4) 20 cholesterol: 10 sphingolipid

72. In an attempt to study the transport of secretory vesicles containing insulin along microtubules in cultured pancreatic cells, how would treatment with "colcemid" affect the transport of these vesicles?

(1) Colcemid induces polymerization of microtubules, which in turn would activate vesicular transport.

(2) Polymerization of microtubules is inhibited by colcemid, which in turn would inhibit the transport of secretory vesicles.

(3) Colcemid inhibits the vesicular trafficking through inactivation of v-SNARE protein.

(4) Colcemid activates t-SNARE, proteins and in turn activates vesicular transport.

73. Glycolipids and sphingomyelin are produced by the addition of sugars or phosphorylcholine to ceramide on cytosolic and luminal surfaces respectively, of the Golgi apparatus. Finally, after such modifications, these molecules are located on the outer half of the plasma membrane. What key events are responsible for such localization?

- (1) Membrane fusion only.
(2) Action of Flippase and membrane fusion.
(3) Action of only Flippase.
(4) Flip flop of these molecules in the golgi membrane catalyzed by proton pump.

74. When circular plasmids having a centromere sequence are transformed into yeast cells, they replicate and segregate in each cell division. However, if a linear chromosome is generated by cutting the plasmid, at a single site with a restriction endonuclease, the plasmids are quickly lost from the yeast. It is known that genes on the plasmids are lost because of the instability of the chromosome ends. What could be done so as to restore its stability and can be inherited?

- (1) Methylation of adenine residues of the plasmid.
(2) Complexing the plasmid ends with histone proteins.
(3) By incorporating telomere sequences to the end of plasmid.
(4) By incorporating acetylated histone proteins to the plasmid ends.

75. Eukaryotic DNA polymerase α has tightly associated primase activity but moderate processivity. DNA

Polymerase ϵ and δ are highly processive but lack primase activity. Given below are four statements about leading and lagging strand synthesis in eukaryotes. Which one is true?

- (1) Both leading and lagging strands are synthesized by DNA polymerase α . Moderate processivity is essential to maintain fidelity of replication.
(2) Entire leading and lagging strands are synthesized by ϵ and δ . Eukaryotic replication is primer independent process.
(3) Only the lagging strand synthesis needs primer and synthesized by DNA polymerase α .
(4) Primers for both the strands are synthesized by DNA polymerase α followed by "Polymerase switching" with ϵ and δ

76. Sting of a bee causes pain, redness and swelling. Melittin is a major peptide in bee venom. Melittin is a membrane binding peptide that is involved in activating phospholipases in the membrane. The possible target phospholipase that is activated by melittin is

- (1) Phospholipase C to generate inositol phosphates.
- (2) Phospholipase A2 to generate arachidonic acid.
- (3) Phospholipase D to generate 1', 3'- inositol.
- (4) Phospholipase A1 to generate palmitic acid

77. Rec 8 is a meiosis specific cohesin that maintains centromeric cohesion between sister chromatids in meiosis I. Which of the phenotypes listed below would you predict will be manifested in a *rec8Δ* yeast?

- (1) Only low viability of dyads.
- (2) Improper reduction division and low viability of tetrads.
- (3) Improper equational division and low viability of dyads.
- (4) Low tetrad viability with no effect on reduction division.

78. The glycolysis and citric acid cycles are important pathways to generate energy in the cell. Given below are statements regarding the production of ATP.

- A. Electrons released during the oxidative steps of glycolysis and citric acid cycle produce 10 molecules of NADH and 2 molecules of, FADH₂ per molecule of glucose.
- B. Electrons released during the oxidative steps of glycolysis and citric acid cycle produce 20 molecules of NADH and 4 molecules of F ADH₂ per molecule of glucose.
- C. The coenzymes produced are oxidized by electron transfer chain.
- D. The conversion of ADP and Pi to ATP takes place in the intermembrane space of mitochondria.

Which one of the following combinations of above statements is correct?

- (1) A and B
- (2) B and C
- (3) C and D
- (4) A and C

79. Hydrogen bonds in proteins occur when two electronegative atoms compete for the same hydrogen atom

Donor-H.....Acceptor The angle ' θ ' between donor and acceptor of a hydrogen bond was determined from large number of X-ray structures of proteins, as shown below:

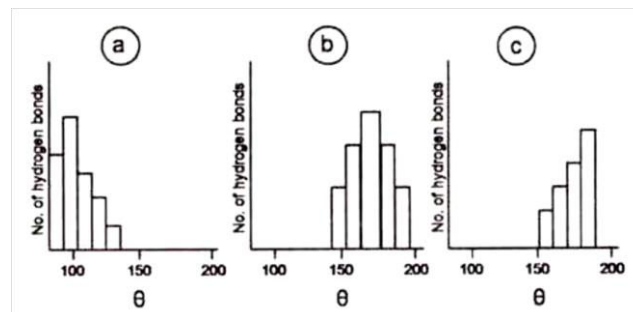

Which one of the distribution of ' θ ' was 'observed from the proteins?

- (1) Only b
- (2) Only a
- (3) Only c
- (4) a and b

80. In a 30-residue peptide, the dihedral angles ϕ/ψ have been determined by one or more methods. When their values are examined in the Ramachandran plot, it is

- (1) not possible for ϕ/ψ values to be distributed in the helical as well as beta sheet region.
- (2) possible that the ϕ/ψ values are all in the helical region although circular dichroism spectral studies indicate beta sheet conformation.
- (3) possible to conclude that the peptide is composed of entirely D-amino acids.
- (4) not possible to conclude if the peptide is entirely helical or entirely in beta sheet conformation.

81. In context to lac operon, if two bacterial strains P₁ and P₂ with the genotypes O_CI⁺Z⁻ and O⁺I⁻Z⁺ respectively, were used to produce mero-diploid daughter strain D, which one of the following statements correctly predicts the expression of Z gene (β -galactosidase activity) in all the three strains? (O⁺, I⁺ and Z⁺ denote the wild type allele of the respective genes).

- (1) P₁ - No expression; P₂ – constitutive expression; D - Inducible expression.
- (2) P₁ - No expression; P₂ – constitutive expression; D – constitutive expression.
- (3) P₁ - No expression; P₂ – Inducible expression; D - Inducible expression.
- (4) P₁ - Inducible expression; P₂ – constitutive expression; D – Inducible expression.

82. In the accompanying figure, reaction kinetics of three proteins (a, b, c) is presented. Protein concentrations used to obtain this data are a – 1 mg/ml; b- 4 mg/ml; c - 2 mg/ml.

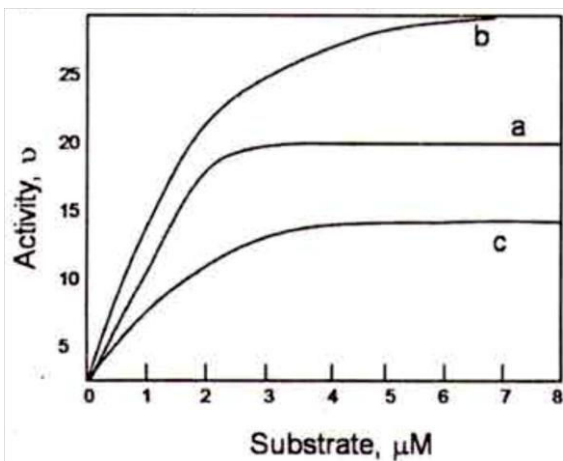

If catalytic efficiency is defined as K_{cat}/K_m , which of the following statements is correct?

- (1) $b > c > a$ (2) $a > b > c$
 (3) $a > c > b$ (4) $c > a > b$

83. The 3' end of most eukaryotic mRNAs is defined by the addition of a polyA tail- a processing reaction called polyadenylation. The addition of poly A tail is carried out by the enzyme Poly(A) Polymerase. Given below are few statements about this process:

- A. Poly(A) Polymerase is a template independent enzyme.
 B. Poly(A) Polymerase catalyses the addition of AMP from dATP to the 3' end of mRNA.
 C. Poly(A) Polymerase is a RNA-template dependent enzyme
 D. Poly(A) Polymerase catalyzes the addition of ADP from ATP to the 3' end of mRNA.
 E. Poly (A) Polymerase catalyzes the addition of AMP from ATP to the 3' end of mRNA.
 F. Poly (A) Polymerase catalyzes the addition of AMP from dADP to the 3' end of mRNA.

Which of the following combination is true?

- (1) B and C (2) C and D
 (3) A and E (4) C and F

84. In order to study the transcription factor TFIIH, it was cloned from a large number of human subjects. Surprisingly, the subjects having mutation in TFIIH, also showed defects in their DNA repair system. Given below are the explanations:

- A. DNA damage is always associated with transcription inhibition.
 B. TFIIH has no role in DNA repair.
 C. In mammalian system, TFIIH plays an active role in transcription coupled. DNA repair process.
 D. Because of mutation in TFIIH, transcription initiation is inhibited and incompletely synthesized mRNAs remain attached to the template DNA leading to DNA damage.

Choose the correct answer.

- (1) A and B (2) C only
 (3) B and D (4) D only

85. With an intention to identify the -genes expressed in an organism at specific stage of development, mRNAs were isolated from the given organism,

cDNAs were synthesized, Cloned in a suitable vector and sequenced. A few of the cDNA sequences showed no matches with the genomic DNA sequence. Further, it was observed that these sequences were U-rich and found to be in stretches dispersed along the sequence. The following may be possible reasons for appearance of such RNA:

- A. Splicing
 B. Alternate splicing
 C. Trans-Splicing
 D. Guide RNA mediated introduction of Us involving endonuclease, terminal-U-transferase and RNA ligase
 E. Deaminations converting C to U Which of the following is the most appropriate reasons?

- (1) A and C (2) B and D
 (3) C, D and E (4) D only

86. A patient with breast cancer was given a dose of radiation along with chemotherapy and was apparently cured of the tumor. After five years, a tumor was noticed in the patient's lungs, but the doctors confirmed that it was derived from cells of the mammary gland.. The following possibilities were suggested by the doctor.

- A. Bacterial infection, after radiation, led to development of the tumors in the lungs.
 B. Migration of residual chemo-resistant cells from the mammary gland resulted in tumors in the lungs.
 C. Epithelial-to-mesenchymal transition had occurred in the lungs.
 D. Cells in the lungs were induced to become a tumor after chemotherapy and from factors secreted by mammary cells:

Which of the following is correct?

- (1) B and D (2) Only B
 (3) A and B (4) A and C

87. Certain chemokines are known to suppress HIV infection whereas proinflammatory cytokines are known to enhance infection. In order to explain these findings, control and chemokine receptor knock-out animals were treated with pro inflammatory cytokines followed by HIV administration and then infection was assessed periodically. Which one of the graphical representation given below best explain the experimental results.

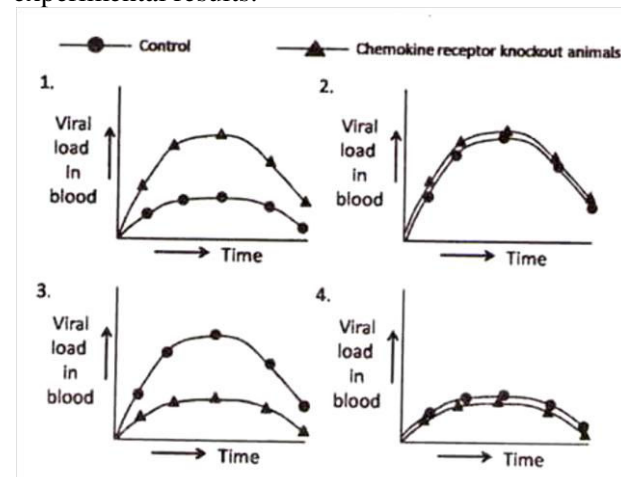

- (1) Fig 1 (2) Fig 2
(3) Fig 3 (4) Fig 4

88. Following are certain statements regarding seed development in plants:

- A. During final phase of development embryo's of "orthodox" seeds became tolerant to desiccation, dehydrate losing up to 90% of water
B. Dormant seeds will germinate upon rehydration while quiescent seeds require additional treatments or signals for the germination
C. Precocious germination is germination of seeds without passing through the normal quiescent and/or dormant stage of development
D. Abscisic acid is known to inhibit precocious germination

Which one of the following combinations is correct?

- (1) A, B and C (2) A, B and D
(3) B, C and D (4) A, C and D

89. When one isolates ribosomes from bacterial lysate, apart from 70S, 50S and 30S ribosomal subunits, one also finds a small population of 100S, 130S and 150S sub-units. EDTA dissociates these larger ribosomal subunits into 50S and 30S, suggesting that they have both the subunits. Upon addition of cations they reassociate into 70S, but none of the other forms could be detected. What is the reason for not obtaining the >70S forms?

- (1) The effects of EDTA cannot be reversed by the addition of cations.
(2) 190S, 130S and 150S are modified form of ribosomes that are irreversibly damaged by EDTA.
(3) 100S, 130S etc. represent polysome that cannot be reassembled *denovo* without other cellular components.
(4) They are obtained as an experimental artifact in preparations of ribosomes.

90. Development of vulva in *C. elegans* is initiated by the induction of a small number of cells by short range signals from a single inducing cell. With reference to this, following statements were put forward.

- A. When the anchor cell was ablated early in development no vulva formed.
B. In a dominant negative mutant of *let-23*, a primary vulva formed but the secondary vulva formation did not take place.
C. A cell adopting a primary fate inhibits adjacent cells from adopting the same fate by lateral inhibition involving LIN-39 and also induces the secondary fate in these cells.
D. A constitutive signal from the hypodermis inhibits the development of both the primary and secondary fates but it is overruled by the initial signal from the anchor cell.

Which of the above statements is true?

- (1) A and B (2) A and C
(3) A and D (4) B and D

91. A cross was made between *Hfr met+ arg+ leu+ strS* X *F- met- arg- leu- strr* in which *leu+* exconjugants are selected. If the linear organization of the genes are *leu+ arg+ met+*, which one of the following genotypes is expected to occur in the lowest frequency?

- (1) *leu+ arg- met-* (2) *leu+ arg+ met-*
(3) *leu+ arg+ met+* (4) *leu+ arg- met+*

92. A researcher was studying a protein 'X' which has been observed to move across cells when an extracellular electrical stimulus is provided. An artificial peptide 'P' was prepared which resembles the structure of connexins and competitively inhibits connexon formation. Which one of the following statements will best explain the fate of protein 'X' if the cells are treated with peptide 'P' and then electrical stimulus is provided.

- (1) X fails to move across cells due to improper formation of tight junctions.
(2) X fails to move across cells due to improper formation of gap junctions.
(3) X moves freely across cells as before.
(4) X fails to move across cells due to improper formation of desmosome.

93. Symbiotic nitrogen fixation. in legume nodules involves complex interaction between *Rhizobium* and legume roots. This complex interaction is governed by

- A. Integration of *sym* plasmid of *Rhizobium* in the root nuclear genome.
B. Sensing of plant flavonoids by rhizobia.
C. Activation of nod genes in rhizobia.
D. Activation of NODULIN genes in legume roots.

Which one of the following combinations is correct?

- (1) A, B and C (2) A, C and D
(3) B, C and D (4) A, B and D

94. What will happen if wingless *RNAi* is expressed in wingless expressing cells from the stage when this gene initiates its expression in a developing *Drosophila* embryo?

- A: The enhanced expression of wingless thus caused will broaden the area of engrailed expression.
B. Since wingless protein makes a long range gradient, its effect will not be seen in the same segment.

C. The posterior compartment of each future segment will get affected.

D. Since engrailed expression is initiated by pair rule genes, the posterior segment will not be affected.

Which one of the following will most appropriately answer the question?

- (1) A and C
- (2) Only C
- (3) B and D
- (4) Only D

95. Which one of the following about development of sea urchin embryos is TRUE?

- (1) Each blastomere of a 4-cell stage possesses a portion of the original animal-vegetal axis and if isolated and allowed to develop will form a complete but smaller size larva.
- (2) Each blastomere of a 8-cell stage has the capacity to form a complete embryo but by the 16-cell stage, blastomeres will develop according to their presumptive fate.
- (3) Any blastomere isolated till the pluteus larva formation will regulate to go on and develop into a full sized embryo.
- (4) After an intricate recombination at the 16 cell stage, the resulting embryo loses its ability to form a complete larva.

96.

Column A	Column B	Column C
i) Invagination	i) Movement of epithelial cells as a unit to enclose deeper layers of the embryo	i) Hypoblast in birds
ii) Involution	ii) Splitting of one cellular sheet into two parallel sheets	ii) Ectoderm in amphibians
iii) Ingression	iii) Infolding of epithelium	iii) Mesoderm in amphibians
iv) Delamination	iv) Migration of individual cells from surface into interior of the embryo	iv) Endoderm in sea urchin
v) Epiboly	v) Inward movement of expanding outer layer so that it spreads over the internal surface of remaining external cells	v) Mesoderm in sea urchin

Which one of the following is the correct combination?

- (1) A (i), B(iv), C(ii)
- (2) A(iv), B(iii), C(i)
- (3) A (iii), B(iv), C(v)
- (4) A(v), B(ii), C(iii)

97. Formation of digits and sculpting the tetrapod limb requires death of specific cells in the limb in a programmed manner. Which one of the following interactions could explain proper limb formation?

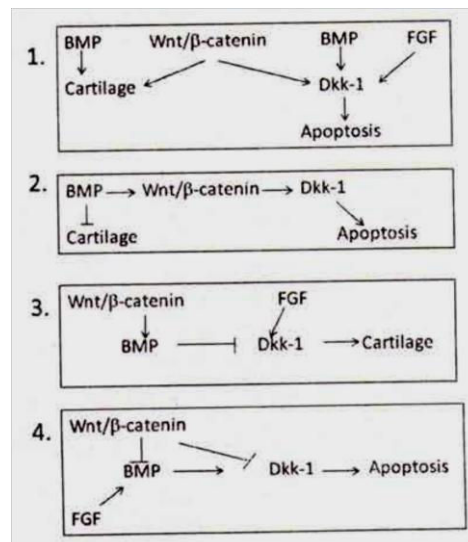

- (1) Fig 1
- (2) Fig 2
- (3) Fig 3
- (4) Fig 4

98. Of the following signaling processes which one is NOT involved in cellular movement or cytoskeletal changes?

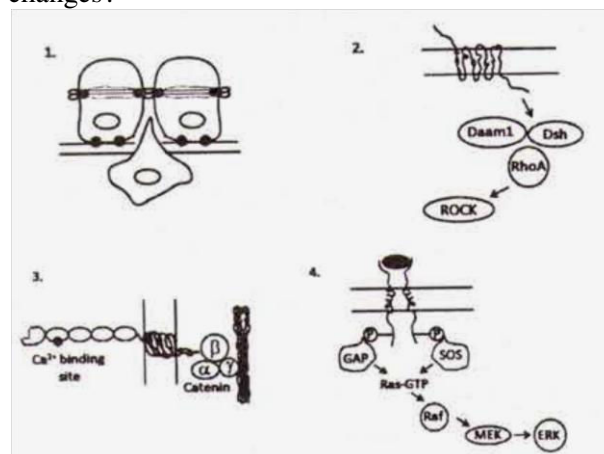

- (1) Fig 1
- (2) Fig 2
- (3) Fig 3
- (4) Fig 4

99. There are three substances A, B and C. Given below are the pattern of immunological responses in rabbits when

- (i) A is administered along with C,
- (ii) B is administered along with C and
- (iii) A is conjugated with B and administered along with C.

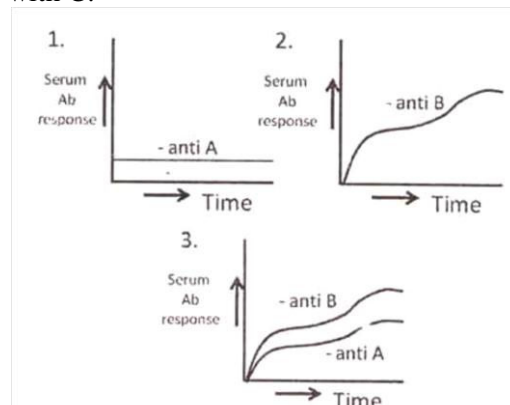

Which one of the following is the correct identification?

- (1) A-protein, B-hapten, C-adjuvant
- (2) A-hapten, B-protein, C- adjuvant
- (3) A-protein, B- adjuvant, C-hapten
- (4) A-hapten, B- adjuvant, C-protein

100. Light is an important factor for plant growth and development. There are several photoreceptors in higher plants such as *Arabidopsis thaliana* involved in perception of various wavelengths of light. Some statements are given below related to photoreceptors:

A. Red light photoreceptors are represented by a gene family.

B. Phytochrome C is the most prominent photoreceptor to perceive red light.

C. Cryptochrome 1 and cryptochrome 2 have evolved from bacterial DNA photolyases.

D. Far-red light is perceived by phytochrome D.

Which one of the following combinations of above statements is correct?

- (1) A and B
- (2) B and C
- (3) C and D
- (4) A and C

101. Chromatin condensation is driven by protein complexes, called condensins which are members of a family of "structural maintenance of chromatin" (SMC) proteins that play a key role in the organization of eukaryotic chromosomes. Condensins along with another family of SMC proteins called cohesins significantly contribute to chromosome segregation during mitosis. If the cells are treated with an inhibitor of cdk 1 phosphorylation immediately before. the cells. enter M phase, which of the following statements is most likely to be true?

- (1) Sister chromatids are held together by condensins along the entire length of the, chromosome.
- (2) Sister chromatids are held together by cohesions along the entire length of the chromosome.
- (3) Sister chromatids are held together by condensins and attached to each other only, at the centromere.
- (4) Sister chromatids are held together by condensins and attached to each other only at the telomere.

102. Two homozygous individuals (P1 and P2), were genotyped using dominant DNA markers A and B, as shown below. The F1 progeny obtained was test crossed and frequency of progeny with which different genotypes appear, is given below:

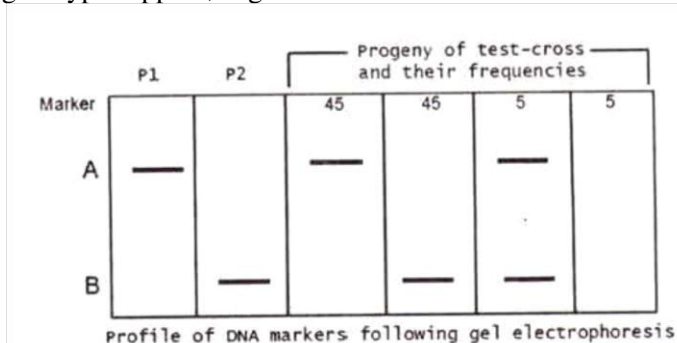

The following conclusions were made:

A. In the F1 markers A and B are linked and in coupling phase (cis)

B. In the F1 markers A and B are linked and in repulsion phase (trans)

C. The distance between A and B is 10 cM

D. The distance between A and a is 5 cM

Which of the above conclusions are correct?

- (1) A and C
- (2) A and D
- (3) B and C
- (4) B and D

103. The below pedigree shows the inheritance of a rare allele. The allele is:

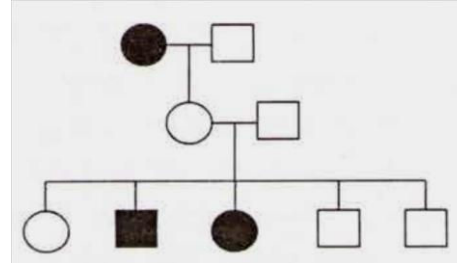

- (1) X-linked recessive
- (2) autosomal recessive
- (3) dominant with incomplete penetrance
- (4) autosomal recessive with incomplete penetrance

104. Pyruvate dehydrogenase is subject to feed back inhibition by its products in glycolysis. Some of the chemical compounds which might be involved in the process, are listed below:

- A. NADH
- B. FADH
- C. Acetyl-CoA
- D. Acetaldehyde

Which one of the following combinations of above chemical compounds is involved in feedback inhibition of pyruvate dehydrogenase?

- (1) A and B
- (2) B and C
- (3) C and D
- (4) A and C

105. Carbohydrates synthesized by photo-synthesis are converted into sucrose and transported via phloem to other parts of the plant. The following aspects are associated with sucrose uploading in phloem and its transport:

- A. Both reducing and non-reducing sugars are transported efficiently through phloem.
- B. Sucrose uploading can be both symplastic and apoplastic.
- C. The route of phloem uploading is- mesophyll cells → phloem parenchyma → companion cells → sieve tubes.
- D. Transport in sieve tubes is as per the 'pressureflow model'.

Which one of the following combinations is correct?

- (1) A, B and C
- (2) B, C and D
- (3) C, D and A
- (4) D, B and A

106. A 'Z' scheme describes electron transport in O_2^- evolving photosynthetic organisms. The direction of electron flow is presented in the following sequences:

- A. $P680^* \rightarrow \text{Pheophytin} \rightarrow \text{QA} \rightarrow \text{QB} \rightarrow \text{PC} \rightarrow \text{Cytochrome b6f} \rightarrow P700$

B. P700* → Phylloquinone → FeSA → FeSB → FeSx → Fd

C. P680* → Pheophytin → QA → QB → Cytochrome b6f → PC → P700

D. P700* → Phylloquinone → FeSx → FeSA → FeSB → Fd

Which one of the following combinations is correct?

- (1) A and B (2) B and C
(3) C and D (4) D and A

107. A plant with red fruit is crossed to a plant with white fruit. The F1 progeny had red fruits. On selfing the F1 two kinds of progeny were observed, plants with red fruits and those with white fruits. To test whether it was a case of recessive epistatic interactions a chi-square test was performed. A value of 1.062 was obtained (chi-square value of $P_{0.05}=3.841$ for Degree of freedom=1). The following statements were made:

- A. The null hypothesis was that plant with red and white fruits will occur in a 9:7 ratio
B. The null hypothesis was that plant with red and white fruits will occur in a 1:1 ratio
C. Based on the chi square value, it is a case of recessive epistatic interactions
D. Based on the chi square value, it is not a case of recessive epistatic interactions

Which of the combination of above statements is correct?

- (1) A and C (2) A and D
(3) Band C (4) B and D

108. During physical exercise, the oxygen supply to the active muscles is increased which has been explained by the following statements:

- A. PO₂ declines and PCO₂ rises in the active muscles
B. The temperature is increased and pH is decreased in active muscles
C. 2, 3-biphosphoglycerate is decreased in RBC and PO₂ rises
D. Metabolites accumulating in the active muscles increase the affinity of hemoglobin to oxygen

Which one of the following is NOT correct?

- (1) A only (2) A and B
(3) B and C (4) C and D

109. Somatic recombination was caused by mild exposure to radiation on flies heterozygous for a given allele during specific stages of development and the individuals were allowed to develop. Such individuals are likely to have

- A. clones of homozygous cells in heterozygous body.
B. site specific mutagenesis.
C. twin spots, i.e., patches of mutants cells and homozygous wild type cells in heterozygous body.
D. tissue specific expression of the given allele.

Which of the following combination of answers will be most appropriate?

- (1) A and B (2) B and C
(3) A and C (4) C and D

110. The fractional clearance of neutral and cationic dextran molecules of various sizes through kidneys of a rat is shown in the figures below. Which one of the following is correct?

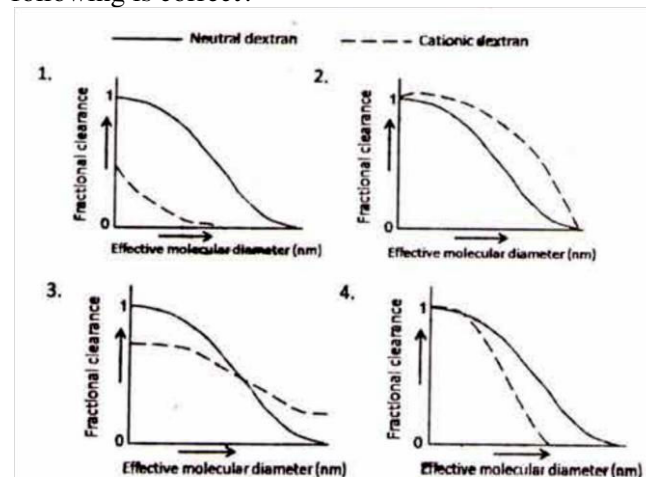

- (1) Fig 1 (2) Fig 2
(3) Fig 3 (4) Fig 4

111. Following are certain statements related to plants exposed to dehydration stress:

- A. When the water potential of the rhizosphere decreases due to water deficit, plants continue to absorb water as long as plant water potential is lower than that of soil water.
B. The ratio of root to shoot growth, increases in response to water deficit
C. Plant cells tend to release solutes to lower water potential during periods of osmotic stress. .
D. Abscisic acid is synthesized at higher rate when leaves are dehydrated, and more ABA accumulates in the leaf apoplast.

Which one of the following combinations of above statements is correct?

- (1) A, B and C (2) B, C and D
(3) A, B and D (4) A, C and D

112. Which one of the following is the most appropriate match for the protected areas of India?

Category	Protected Area
A. Biosphere Reserve	(i) Chambal
B. National Park	(ii) Loktak
C. Ramsar Site	(iii) Nanda Devi
D. Wildlife Sanctuary	(iv) Rajaji
	(v) Sunderbans

- (1) A: (iii) B- (iv) C-(ii) D-(i)
(2) A: (ii) B- (iv) C-(iii) D-(i)
(3) A: (i) B- (v) C-(iii) D-(i)
(4) A: (iii) B- (ii) C-(v) D-(iv)

113. Estradiol synthesis follows a 2 cell-2-gonadotropin theory, where partial synthesis occurs in the granulosa cells and the rest in the theca interna cells of the Graafian follicle. Which of the following correctly represents estradiol synthesis and secretion?

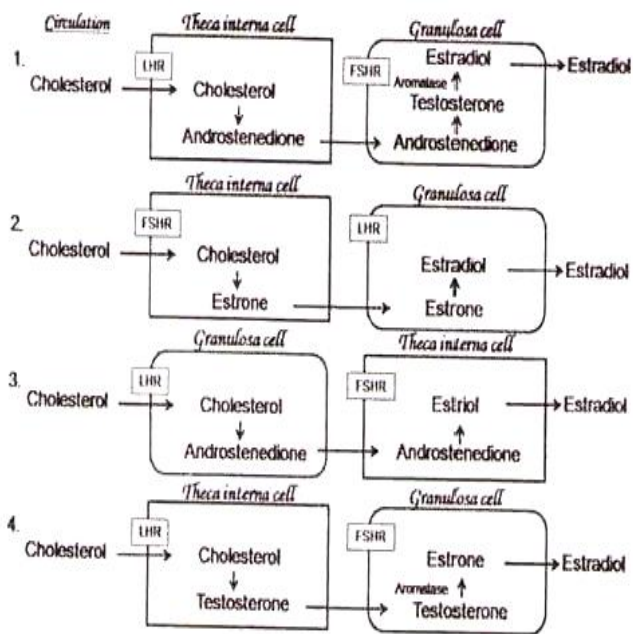

- (1) Fig 1 (2) Fig 2
 (3) Fig 3 (4) Fig 4

114. Sickle cell anemia is a recessive genetic disease caused due to a point mutation in the 6th codon abolishing one of the *MspII* endonuclease digestion site present in the β -globin gene. *MspII* digested DNA from a normal person gives two bands, 1150 bp and 200 bp, in β -globin gene. A family with a proband (based on the disease phenotype) gave the following *MspII* digestion pattern:

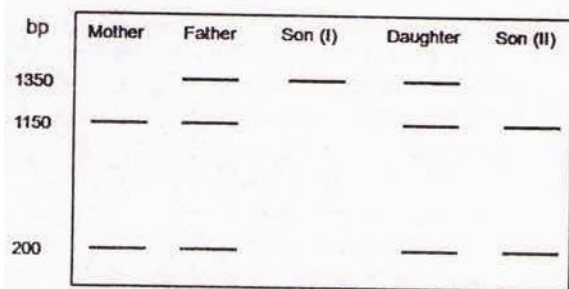

- The following conclusions were drawn:
 A. Son (I) is the proband and the given mutation is not present in Son (II).
 B. The daughter is a carrier for the given mutation.
 C. The gene is X-linked and thus Son (I), becomes the proband.
 D. The father and daughter are affected
 E. A de novo mutation in same site on normal allele has allowed appearance of diseased phenotype in the proband

Which of the following combination of conclusions will be the most appropriate for the figure given above?

- (1) A, B and E (2) A, B and C
 (3) B, C and E (4) C and D

115. The mechanism of sound localization in a 'horizontal plane' by the human auditory system can be explained by

- A. the difference in time between the arrival of stimulus in two ears
 B. the difference in phase of the sound waves on two ears
 C. the difference in tuning curves of two auditory nerves
 D. the activity of neurons in superior olivary nucleus, but not by the neuronal activity of auditory cortex

Which one of the following is NOT correct?

- (1) Only A (2) A and B
 (3) B and C (4) C and D

116. The following table shows selected characters used in analyzing the phylogenetic relationships of four plant taxa:

Taxon	Characters			
	Xylem or Phloem	Wood	Seed	Flowers
T1	+	-	-	-
T2	+	+	+	+
T3	+	+	+	-
T4	-	-	-	-

Taxa T1, T2, T3 and T4 are respectively:

- (1) Ferns, Oaks, Pines, Hornworts
 (2) Oaks, Pines, Hornworts, Ferns
 (3) Hornworts, Pines, Oaks, Ferns
 (4) Ferns, Pines, Oaks, Hornworts

117. In high altitude, hypoxia induces increased number of circulating red blood cells, which can be explained by the following changes:

- A. The transcription factors, HIFs are produced.
 B. Erythropoietin secretion is increased
 C. Myoglobin content is decreased
 D. Cytochrome oxidase is decreased
- Which one of following is NOT true?
 (1) Only A (2) A and B
 (3) B and C (4) C and D

118. Given below are the characteristics of a few mammalian order. Match the names of the animals with the characteristics of their orders:

- A. Hooves with even number of toes on each foot, omnivorous
 B. Teeth consisting of many thin tubes cemented together, eats ants and termites
 C. Opposable thumbs, forward facing eyes, well developed cerebral cortex, omnivorous.
 D. Hooves with an add number of toes on each foot; herbivorous
- (i) Tapir (ii) Lemur
 (iii) Aardvark (iv) Pig

Choose the correct combination

- (1) A- (iii) B- (iv) C- (i) D- (ii)
 (2) A- (i) B- (iv) C- (ii) D- (iii)
 (3) A- (iv) B- (iii) C- (ii) D- (i)
 (4) A- (iv) B- (iii) C- (i) D- (ii)

119. Which of the following is true about the Digestion Efficiency (DE)-(assimilation/consumption) and Ecological Efficiency (EE) (production/consumption) of ectotherms and endotherms?

- (1) Endotherms have a high DE and ectotherms have a high EE. .
- (2) Endotherms have a low DE and ectotherms have a high EE.
- (3) Endotherms have a high DE and ectotherms have a low EE.
- (4) Endotherms have a low DE and ectotherms have a low EE.

120. Given below is a matrix of possible interactions beneficial. (+), harmful (-), Neutral (0) between species 1 and 2. The names of interactions, A, B, C and D, respectively; are

		Species 1		
		+	-	0
Species 2	+	C	B	
	-		A	D

- (1) Predation, competition, mutualism, commensalism
- (2) Mutualism, competition, amensalism, commensalism
- (3) Competition, predation, mutualism, amensalism
- (4) Competition, mutualism, commensalism, predation

121. Which of the following is/are NOT valid explanation(s) for the observed pattern of species richness?

- A. Older communities are more species rich.
- B. Large areas support more species.
- C. Natural enemies promote reduced species richness at local level.
- D. Communities in climatically similar habitats may themselves be similar in species richness.
- E. Greater productivity permits existence of more species.

- (1) B, C and D
- (2) Only C
- (3) Only D
- (4) A, B and E

122. Two lakes (I and II) with a similar trophic structure of phytoplankton-zooplankton, planktivorous fish food chain were chosen. To understand the 'top-down' effects, some piscivorous fish (those that feed on planktivorous fish) were introduced into Lake I, making it a system with four trophic levels. Lake II was enriched by adding large quantities of nitrates and phosphates to study the 'bottom-up' effects over a period of time. Changes in the biomasses of each trophic level were measured. The expected major changes in the two lakes are

- (1) In Lake I zooplankton biomass increases, phytoplankton biomass decreases. In Lake II both phytoplankton and planktivorous fish biomasses increase.
- (2) In Lake I zooplankton biomass decreases, phytoplankton biomass increases. In Lake II both phytoplankton and planktivorous fish biomasses increase.
- (3) In Lake I planktivorous fish biomass and phytoplankton biomass decrease. In Lake II phytoplankton biomass increases, planktivorous fish biomass decreases.
- (4) In Lake I planktivorous fish and zooplankton biomasses increase. In Lake II both phytoplankton and planktivorous fish biomasses increase.

123. The following table shows the number of individuals of each species found in two communities:

Community	Species			
	A	B	C	D
C1	25	25	25	25
C2	80	05	05	10

(Hint: In values for 0.05, 0.10, 0.25 and 0.80 are -3.0, -2.3, -1.4 and -0.2, respectively)

The calculated Shannon diversity index (H) values for communities C1 and C2, respectively are

- (1) 1.4 and 0.69
- (2) 1.2 and 0.34
- (3) 2.1 and 0.43
- (4) 1.8 and 0.37

124. In a population at Hardy-Weinberg equilibrium, the genotype frequencies are: $f(A_1A_1) = 0.59$; $f(A_1A_2) = 0.16$; $f(A_2A_2) = 0.25$. What are the frequencies of the two alleles at this locus?

- (1) $A_1 = 0.59$ $A_2 = 0.41$
- (2) $A_1 = 0.75$ $A_2 = 0.25$
- (3) $A_1 = 0.67$ $A_2 = 0.33$
- (4) $A_1 = 0.55$ $A_2 = 0.44$

125. Following are the main types of defense employed by prey species against predators Types of defense: Chemical with aposematic coloration (A); Cryptic coloration (B); Batesian mimicry (C); Intimidation display (D) Prey Species: Grasshoppers and seahorses (i); Hoverflies and wasps (ii); Bombardier beetles, ladybird beetles, many butterflies (iii); Frilled lizard, Porcupine fish (iv) Which one of the following combinations is correct?

- (1) A-(i) B-(iii) C-(ii) D (iv)
- (2) A-(iv) B-(ii) C-(i) D (iii)
- (3) A-(iii) B-(i) C-(ii) D (iv)
- (4) A-(ii) B-(iii) C- (i) D- (iv)

126. In the evolutionary tree given below terms A, B, C, D and E represent respectively

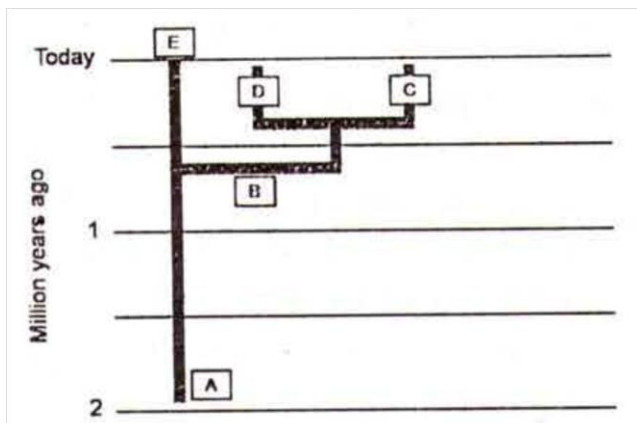

(1) *Homo erectus*, *Homo heidelbergensis*, Neanderthal, Denisovan and *Homo sapiens*.

(2) *Homo heidelbergensis*, *Homo erectus*, Denisovan, Neanderthal and *Homo sapiens*.

(3) *Homo erectus*, *Homo heidelbergensis*, Denisovan, Neanderthal and *Homo sapiens*.

(4) *Homo heidelbergensis*, *Homo sapiens*, Denisovan, Neanderthal, and *Homo erectus*.

127. Which of the following options match the plant tissue type with its correct function in vascular plants?

Tissue	Function
A. Tracheids	(i) Chief water conducting elements in gymnosperms
B. Vessel elements	(ii) Chief water conducting elements in angiosperms
C. Sieve tube elements	(iii) Food conducting elements in gymnosperms
D. Sieve cell	(iv) Food conducting elements in angiosperms

(1) A-(i) B-(ii) C-(iv) D-(iii)

(2) A-(ii) B-(i) C-(iii) D-(iv)

(3) A-(i) B-(ii) C-(iii) D-(iv)

(4) A-(i) B-(iii)C-(iv) D-(ii)

128. Following is the list of some important events in the history of life and the names of the epochs of Cenozoic era.

Events

A. Angiosperm dominance increases; continue radiation of most present day mammalian orders

B. Major radiation of mammals, birds and pollinating insects

C. Origins of many primate groups

D. Origin of genus *Homo*

E. Appearance of bipedal human ancestors

F. Continued radiation of mammals and angiosperms, earliest direct human ancestors

Epochs I

(i) Paleocene (ii) Pleistocene (iii) Oligocene (iv)

Pliocene (v) Eocene (vi) Miocene

Which one of the following is the correct match of events with the epochs?

(1) A-(v) B-(ii) C-(i) D-(iii) E-(iv) F-(vi)

(2) A-(vi) B-(i) C-(ii) D-(iv) E-(iii) F-(v)

(3) A-(v) B-(i) C-(iii) D-(ii) E-(iv) F-(vi)

(4) A-(iv) B-(i) C-(ii) D-(iii) E-(v) F-(vi)

129. Which of the following gives the correct human disease- causal microbe match for each?

Human Disease	Causal Microbe
A. Chronic gastritis	(1) <i>Borrelia burdorferi</i>
B. Lyme disease	(2) <i>Helicobacter pylori</i>
C. Scarlet fever	(3) <i>Rickettsia prowazekii</i>
D. Typhus	(4) <i>Streptococcus pyrogenes</i>

(1) A - (ii) B - (i) C - (iv) D - (iii)

(2) A - (ii) B - (iii) C - (i) D - (iv)

(3) A - (iv) B - (i) C - (ii) D - (iii)

(4) A - (iv) B - (iii) C - (i) D- (ii)

130. Match the five (A -E) group of organisms with their correct taxonomic rank (i - v) given below:

Group	Taxonomic rank
A. Crustacea	(i) Order
B. Hominidae	(ii) Domain
C. Dermoptera	(iii) Class
D. Ctenophora	(iv) Phylum
E. Archae	(v) Family

(1) A- (iii), B-(i), C- (v), D- (iv), E- (ii)

(2) A- (i), B-(ii), C- (iii), D- (iv), E- (v)

(3) A- (iv), B-(iii), C- (ii), D- (i), E- (v)

(4) A- (iii), B-(v), C- (i), D- (iv), E- (ii)

131. Compared to K-selection, r-selection favours

(1) rapid development, smaller body size and early, semelparous reproduction.

(2) rapid development, smaller body size and early, iteroparous reproduction.

(3) slow development, larger body size and late, iteroparous reproduction.

(4) slow development, smaller body size and late, iteroparous reproduction

132. Homing pigeons, when released at a place far away from their home, use earth's magnetic field or the sun as navigational cues and choose the right direction to fly. To test the hypotheses, two experiments were conducted. In Experiment I, one group of pigeons (Test) were equipped with Helmholtz coils (which disrupt magnetic field detection), while the second group (Control) were not. Both groups were released on a sunny day.

Experiment II used the same Control and Test groups of pigeons, but they were released on a cloudy, overcast day. The expected results, if the hypotheses is true, would be

(1) In Experiment I, both Control and Test groups fly in the right direction, but in Expt. II, only Control group does.

(2) In both experiments, Test groups fail to choose the right direction.

(3) In Experiments I and II; Test groups fly in the right direction.

(4) In Experiment I both groups fly in the right direction but in Expt. II both groups fail to choose the right direction.

133. Brothers A and B have the same father but different mothers. B wants A to help him, which involves both benefits (b) and costs (c) for A. If A incurs a cost of 30 'Darwinian fitness units' in that act, under what condition, should he help B, following Hamilton's rule?

- (1) only if $b > 30$ (2) only if $b > 60$
 (3) only if $b > 120$ (4) only if $b > 240$

134. A protein undergoes post-translational modifications. In an experiment to identify the nature of modifications, the following experimental results were obtained.

- A. Protein moved more slowly in an SDS PAGE.
 B. Isoelectric focusing (IEF) showed that there was no change in the pI.
 C. Mass spectrometric analysis showed that the modification was on serine

The modification that the protein undergoes is likely to be

- (1) phosphorylation
 (2) glycosylation
 (3) ubiquitination
 (4) ADP-ribosylation

135. In transgenic mice, the orientation and location of the loxP sites determine whether Cre recombinase induces a deletion, an inversion or a chromosomal translocation. If a researcher wants to put loxP sites in such a manner that only inversion will take place, which one of the following constructs best justifies their intention. Gene X is the target gene.

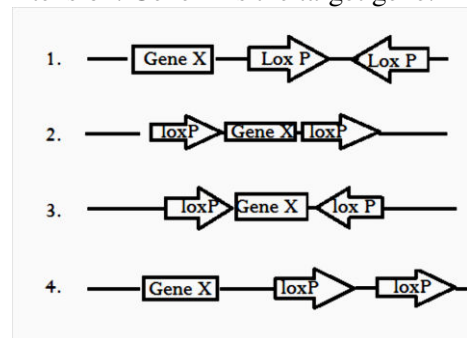

- (1) Fig 1 (2) Fig 2
 (3) Fig 3 (4) Fig 4

136. For the aquaculture farming of Indian major carps several techniques are used. Which one of the following is NOT used for this purpose:

- (1) Induced breeding
 (2) Selective breeding
 (3) Inbreeding
 (4) Composite fish farming

137. A gene from genomic library is screened by using hybridization technique. After hybridizing the probe, usually a stringent washing step is given. The following statements are given to explain the stringent washing step:

- A. Stringent washing takes care of removing unincorporated and non-specifically hybridized probe molecules
 B. Stringent washing is done in solution having high salt concentration and lower temperature
 C. Stringent washing is done in solution having low salt concentration keeping higher temperature
 D. Salt present in washing solution supports hybrids to stay intact by shielding the interference of water molecules
 E. Salt reacts with DNA molecules and allows easy dissociation of hybrids
 F. Stability of hybrid is directly proportional to the temperature

Which combination of the above statements is most appropriate for stringent washing, step?

- (1) A, B and D (2) A, C and D
 (3) A, B and F (4) C, E and F

138. In a confirmatory test for HIV, one or more viral antigens are detected in the blood of patients. Following are the steps to be performed for the experiment:

- A. Transfer of viral antigens to nitrocellulose paper
 B. Incubation with the buffer containing antibodies specific for viral antigens.
 C. Separation of viral antigens by SDS-PAGE
 D. Detection of bands by enzyme-linked secondary antibody

Identify the correct sequence steps to be performed for the experiment.

- (1) A-B-C-D (2) B-C-D-A
 (3) C-A-B-D (4) C-B-A-D

139. In response to a drug, changes in protein levels were examined in a cell line. A pulse chase experiment was performed using ^{35}S labeled methionine. In comparison, to untreated samples, the following observations were made: few minutes after stimulation, protein X accumulates and this was followed by reduction in protein Y and Z. The correct interpretation of these observations would be:

- (1) Protein X is a protease which degrades Y and Z.
 (2) Protein X is a transcriptional repressor that controls expression of Y and Z.
 (3) Expression of protein X and loss of Y and Z are unrelated.
 (4) Information is not sufficient to distinguish between the three possibilities stated above.

140. A student while constructing knock-out mice isolated mouse embryonic, stem cells and introduced an engineered DNA into the cells. However, none of the mice were transgenic. On checking the cells containing DNA construct, he found that he had made a mistake in constructing the DNA since the cells were resistant to gancyclovir but sensitive to G418. Which one of the following constructs had he designed

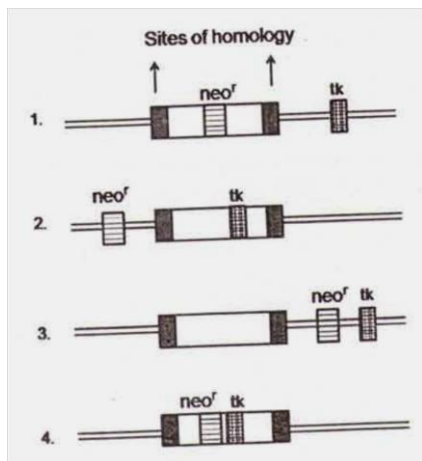

- (1) Fig 1 (2) Fig 2
(3) Fig 3 (4) Fig 4

141. The most important property of any microscope is its resolution (D) and can be calculated from the formula

$$D = \frac{0.61\lambda}{N \sin \alpha}$$

Where D is, minimum distance between two distinguishable objects, λ is the wave length of incident light, α is, the angular aperture and N is the refractive index of the medium. Given below are several suggestions to improve the resolution of a microscope:

- A. decrease the wave length of incident light
B. increase the wave length of incident light
C. use oil which has a higher refractive index
D. use oil because of its lower refractive index

Which one is the correct suggestion?

- (1) A and C (2) Only B
(3) Only D (4) B and D

142. The mean and standard deviation of serum cholesterol in a population of senior citizens are assumed to be 200 and 24mg/dl, respectively. In a random sample of 36 senior citizens, what values of cholesterol (to the nearest whole number) should lead to rejection of the null hypothesis at 95% confidence level?

- (1) above 224
(2) above 248
(3) below 176 and above 224
(4) below 192 and above 208

143. The following genes have been genetically engineered to develop herbicide resistance in plants:

- A. Resistance to glyphosate using the 5-enolpyruvyl shikimate-3-phosphate synthase gene
B. Bialaphos resistance using the bar gene
C. Sulfonyl urea resistance using the acetolactate synthase gene
D. Atrazine resistance using the glutathione Stransferase gene .

In which of the above two cases the mechanism is based on abolition of herbicide binding to the enzyme?

- (1) A and D (2) B and C
(3) C and D (4) A and C

144. Somatic embryogenesis is an important exercise in micropropagation and genetic engineering of plants. The following steps are considered as critical for achieving somatic embryogenesis:

- A. Reducing the concentration of sucrose in the medium by half.
B. Addition of the hormone, 2, 4-dichlorophenoxyacetic acid to induce somatic embryos.
C. Reduce agar concentration to 0.6% (w/v)
D. Use maltose in place of sucrose as a carbon source

Which one of the following combinations is correct?

- (1) A and C (2) B and D
(3) A and B (4) C and D

145. Factor IX is essential for blood clotting. Deficiency of Factor IX could be corrected by delivering factor IX gene using viral vectors. In an experiment the gene for Factor IX was cloned appropriately into Adenovirus (AV), Adenoassociated virus (AAV) and Retrovirus (RV).

Retrovirus integrate the gene into the dividing cells. AAV integrates partially into non-dividing cells. AV does not integrate the gene but transfects both dividing and non-dividing cells. Following expression profile for Factor IX was

observed when the three vectors were injected intramuscularly into three groups of experimental mice. Which one of the following outcomes is correct?

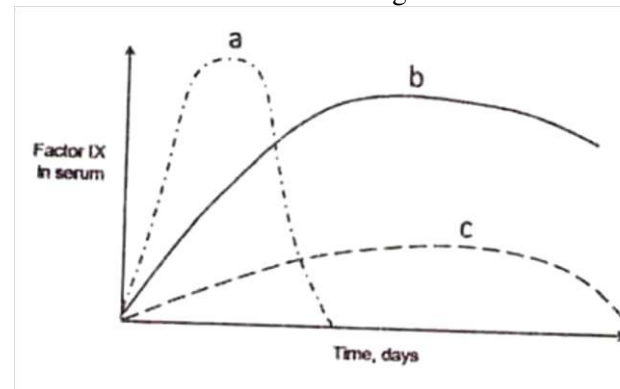

- (1) a by RV; b by AV; c by AAV
(2) a by AV; b by AAV; c by RV
(3) a by AA V; b by RV; c by AV
(4) a by AV; b by RV; c by AAV